

BREMA DRB500

ICE STORAGE BIN WITH TROLLEYS

The DRB500 is a stainless steel structure with two 108kg capacity polyethylene moulded trolleys for transporting ice cubes or flakes.

When coupled with a modular head, the DRB500 generously stores ice to meet peak demand times for a range of applications.

Can be coupled with: G500/1000,
G500 (x2), M600/800/1500



STANDARD FEATURES

- Bay storage capacity of 300kg
- 108kg storage capacity per trolley
- Can be coupled with a range of Brema modular ice machine heads
- Stainless steel structure
- Polyethylene moulded trolleys
- Piano-hinged door

SPECIFICATIONS ARE SUBJECT TO CHANGE WITHOUT NOTICE.

From the world of Comcater!

National Head Office
156 Swann Drive
Derrimut VIC 3030
Tel: +61 3 8369 4600
Fax: +61 3 8369 4695

Melbourne
96-100 Tope Street,
South Melbourne VIC 3205
Tel: +61 3 8369 4600
Fax: +61 2 8699 1299

Sydney
20/4 Avenue of the Americas
Newington, NSW 2127
Tel: +61 2 9748 3000
Fax: +61 2 9 648 4762

Brisbane
1/62 Borthwick Avenue
Murarrie QLD 4172
Tel: +61 7 3399 3122
Fax: +61 7 3399 5311

BREMA DRB500

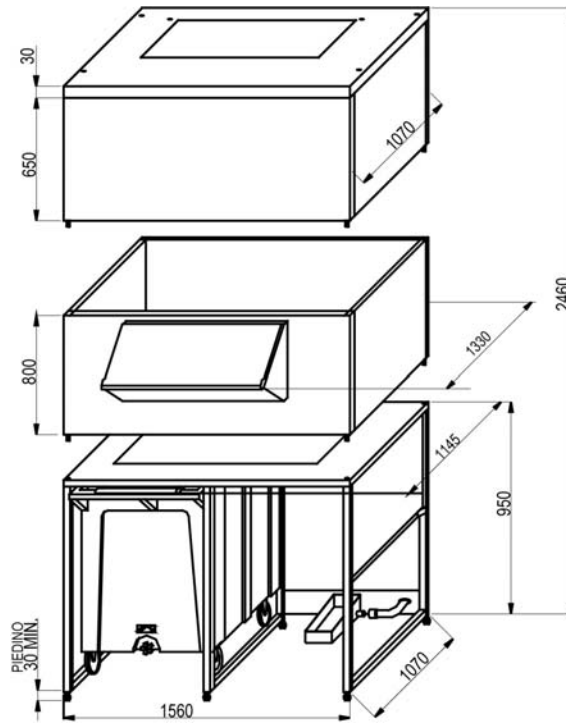

DIMENSIONS

1560W x 1145D x 1780H mm

USABLE WITH MODULAR HEADS

G500/1000, G500 (x2), M600/800/1500

TECHNICAL DATA

Storage Capacity	516 Kg	
Weight	204 kg	
Clearances	Rear:	Sides:
	100 mm	100 mm

STANDARD ACCESSORIES

- Drainage hose
- Plastic Ice Scoop

SPECIFICATIONS ARE SUBJECT TO CHANGE WITHOUT NOTICE.



www.comcater.com.au

PROUDLY DISTRIBUTED BY: