



Electrolux

Warewashing
Pot&Pan Washer with Automatic
Hood and Front/Side Feeding, Multi-
Rack Support 1433mm

ITEM # _____

MODEL # _____

NAME # _____

SIS # _____

AIA # _____



Electrolux



Warewashing

Pot&Pan Washer with Automatic Hood
and Front/Side Feeding, Multi-Rack
Support 1433mm

506066 (EPPWEALMS)

Pot&pan washer, automatic
hood, front/side feeding with
multi-rack support

Short Form Specification

Item No. _____

304 AISI stainless steel front and side panels, wash tank, tank filter and wash and rinse arms. Double skinned, insulated, hood with automatic opening and closing with safety switch. N. 4 washing cycles and a self-cleaning cycle.

Built-in atmospheric, insulated water boiler (10,5 kW), 18-liter capacity, combined with rinse booster pump guarantee a constant hot rinse temperature of 84°C. Boiler with 304 welding for protection against corrosion.

Wash Safe Control assures the correct water temperature and pressure during the rinse phase to guarantee a perfect rinsing performance independent from the water pressure in the network (min. 0,5 bar).

Thermometer. Electronic control board with digital display.

Pre-arrangements for connection to an automatic detergent dispenser.

Direct through-feed using loading/unloading tables or front-feed loading.

Cell dimensions mm1270x610x620h.

Load capacity: n.6x1/1 GN.

Supplied with: n. 1 basket in stainless steel and n. 2 racks for containers and trays.

Main Features

- Simple service from the front.
- 4 washing programs (one program is continual).
- Atmospheric insulated boiler combined with the rinse booster pump for perfect rinsing results (water temperature and pressure always constant during rinsing cycles), independent from the inlet water pressure.
- Automatic start on hood closure.
- Direct through-feed using loading or unloading tables or front-feed loading.
- Large strainer boxes above the water surface and extra strainer in the tank bottom at the pump inlet.
- Self-cleaning cycle to automatically sanitize the dishwasher after use.
- Automatic hood opening and closing through safety switch.
- Final rinse only starts when the correct temperature has been reached (waiting device).
- Pre-arrangements for automatic detergent and rinse-aid dispenser.
- Electronic control panel and digital display.
- Adjustable pressure for the lower wash system, according to the weight of the items being washed.
- Automatic boiler empty button.
- Low noise level.
- Easy to remove wash/rinse arms.

Construction

- Unit to feature smooth surfaces to facilitate cleaning.
- Finished in top quality materials to ensure durability.
- 304 AISI stainless steel front and side panels, wash tank, tank filter and wash and rinse arms.
- No pipes inside the washing chamber.
- Double-walled construction reduces the levels of noise and heat emitted.
- Double rack support suitable to use also standard rack of 500x500mm.

Included Accessories

- 2 of Extra rack for containers and trays PNC 864182
- 1 of Extra stainless steel basket for pot washer 1300mm PNC 864190

Optional Accessories

- Integrated HACCP kit PNC 864001
- HACCP printer kit PNC 864002
- Filter for partial demineralization PNC 864017
- Kit to measure total and partial water hardness PNC 864050
- Extra rack for containers and trays PNC 864182
- Front shelf for pot washer 1300mm PNC 864188
- Extra stainless steel basket for pot washer 1300mm PNC 864190
- Filter for total demineralization PNC 864367

APPROVAL: _____



Electrolux

Warewashing
Pot&Pan Washer with Automatic Hood
and Front/Side Feeding, Multi-Rack
Support 1433mm

Front

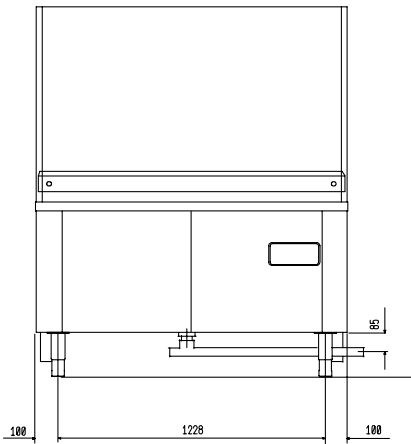

Top

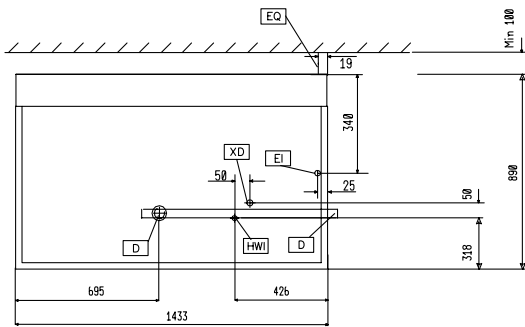

- D = Drain
- EI = Electrical connection
- EO = Electrical Outlet
- EQ = Equipotential screw
- HWI = Hot water inlet
- V = Air vents
- XD = Detergent connection
- XR = Rinse aid connection

Side

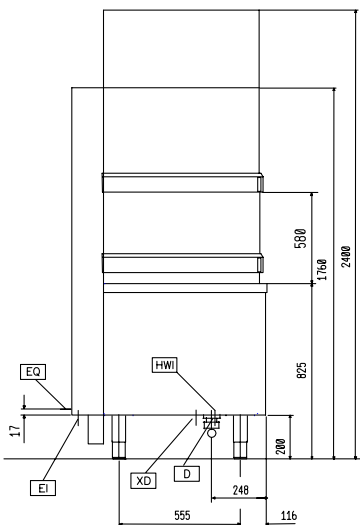

Electric

Supply voltage:	400 V/3N ph/50 Hz
Default Installed Power:	15.5 kW
Electrical power:	26 kW
Total Installed Power:	26 kW
Boiler heating elements:	10.5 kW
Rinse pump power:	0.28 kW

Water:

Pressure:	0.5-7 bar
Water supply temperature:	50 °C
Working cycles time (sec.):	180/360/540/inf
Boiler Capacity (lt):	18
Inlet water supply hardness (MAX):	
Washing cycle temperature:	55-65 °C
Washing cycle tank capacity (lt):	110
Washing cycle pump power:	5 kW
Washing cycle electrical elements:	10.5 kW
Hot rinse cycle duration (sec.):	20
Hot rinse cycle temperature:	84 °C
Hot rinse cycle water consumption (lt):	7.7

Key Information:

N° of working cycles - sec.:	4 (180/360/540/inf)
External dimensions, Height:	1760 mm
External dimensions, Width:	1433 mm
External dimensions, Depth:	890 mm
Net weight:	270 kg
Noise level:	<70 dBA
Cell dimensions - width:	1270 mm
Cell dimensions - depth:	610 mm
Cell dimensions - height:	580 mm
Rinsing water consumption (per cycle):	7.7 lt



Warewashing
Pot&Pan Washer with Automatic Hood and Front/Side Feeding, Multi-Rack Support 1433mm
The company reserves the right to make modifications to the products without prior notice. All information correct at time of printing.